

**Schneider Electric combines PAC
with Ethernet Backbone
The world's first ePAC**



Schneider Electric Industry Business
www.schneider-electric.com
02 9125 8000

Schneider
Electric™

ARC WHITE PAPER

By ARC Advisory Group

NOVEMBER 2013

Schneider Electric Introduces First ePAC, Combines PAC with Ethernet Backbone

| | |
|--|----|
| Executive Overview | 2 |
| Latest Trends and Market Drivers | 3 |
| Schneider Electric's New Modicon M580 ePAC | 5 |
| M580 ePAC Value Propositions | 7 |
| M580 ePAC Competitive Differentiators | 10 |
| M580 ePAC Target Applications | 14 |
| Summary and Conclusions | 16 |



Executive Overview

As a hub for both real-time control and information, PACs can benefit from being designed with an open Ethernet backbone to optimize connectivity and communications, increase bandwidth, and provide a high level of security.

To obtain the various multi-disciplinary functionalities needed to run their plants, process end users in industries such as water & wastewater, food & beverage, metals & mining, hydropower, and cement & glass expect secure, reliable interoperability among their automation products. This need for functional interoperability has resulted in automation solutions that employ a multitude of different drivers, networks, and standards. However, interoperability becomes less critical if a single product can provide a large percentage of the required functionality. This has led to the growth of the multi-disciplined controller, which ARC Advisory Group dubbed the *programmable automation controller*, or PAC, back in 2002.

PACs typically provide complete automation, real-time information, and motion control functionality using a single programming and engineering tool and a single programming language. PACs provide transparent access across all parameters and functions, along with easy integration to the enterprise through the use of Internet and other IT standards.

As the needs of process end users continue to evolve to meet their ever-increasing challenges for productivity, flexibility, efficiency, and profitability, the designs of PACs have also evolved. PACs must leverage the latest and most powerful silicon offerings in hardware to increase robustness and the reliability of the memory. PACs must also provide a high memory capacity to avoid creating bottlenecks.

With today's process plants requiring more rapid changeover capabilities as the life cycles of the products produced continues to shrink and consumer demand constantly shifts, it is critical to be able to change automation configurations and architectures on the fly, without stopping the process. As a hub for both real-time control and information, PACs can benefit from being designed with an open Ethernet backbone to optimize connectivity and communications, increase bandwidth, and provide a high level of security. PACs must also have an architecture geared for maximizing production flexibility, data and information transparency, and openness for diagnostics performed both locally and remotely. This has led to the next evolution of the PAC, an evolutionary new concept defined by Schneider Electric as the ePAC.

Latest Trends and Market Drivers

ARC has observed a major trend for process end users to employ open networking technologies, such as EtherNet/IP, to be able to take advantage of an open integration environment, higher information bandwidth,

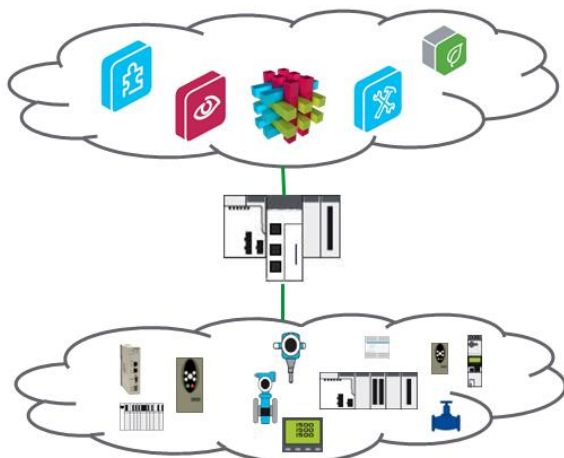

ePACs Help Link Cloud-Based Applications to the Plant

standardization, cost savings, the flexibility to physically move portions of their processing, and increased data visibility at all levels. The increasing need for distributed intelligence makes networking critically important. This market driver is leading to increased adoption of ePACs with built-in Ethernet backbones, especially for connectivity to either on-premise or cloud-based enterprise applications, such as enterprise resource planning (ERP), manufacturing execution systems (MES), enterprise asset management (EAM), and supply chain management (SCM).

Today's connected applications demand tighter integration and more information, with a higher expectation that the control system will initiate communication, update the controller at the device level in real time, and serve up potentially massive quantities of information. Automation platforms with a built-in Ethernet backbone help meet these requirements in a highly flexible manner because they can support instant access, regardless of hierarchy, and avoid the limitations of proprietary software interfaces and protocols.

Network-centric ePACs with a built-in Ethernet backbone are accelerating the trend towards distributed I/O, providing process end users with significant cabling cost savings and reductions in installation, start-up and commissioning costs. Using Ethernet cables to replace I/O extension cables and field bus cables can result in significant cabling cost savings. Ethernet cables are also much less expensive than even standard coaxial cables. In addition, the use of single optical fibers to connect long distance remote drops and devices can also result in significant cabling cost savings. ePACs create new opportunities for both traditional in-rack applications as well as for distributed I/O.

At the control level, process end users seek an increasingly more flexible, expandable, interchangeable, and reliable control platform that, ideally, covers the widest range of required applications. They're looking for the ability to easily interface their control platforms with both fixed/wired and mobile/wireless HMIs, serial devices, motors, thermocouples, analog and digital I/Os, and other equipment and devices. Since control room and rack space is at a premium, they want automation platforms with the smallest practical footprint. And since power consumption affects both electricity and air conditioning costs, they're looking for more energy-efficient solutions.

System modernization issues are becoming more important than ever. Several years ago, ARC estimated that worldwide, about \$65 billion in installed process automation systems are reaching the end of their useful life, with most over 20 years of age. An example of end of useful life is not meeting the requirements for today's emerging threat, such as the inclusion of a sufficient cybersecurity scheme. This figure is likely to be even larger

To address the latest automation trends and market drivers for global process end users, Schneider Electric has introduced a new programmable automation controller platform with a built-in Ethernet backbone. Called the Modicon M580 ePAC, (Ethernet PAC), this new concept is designed to fill the void between a universal Ethernet backbone, a DCS, and a PAC.

today. When evaluating automation system modernization projects, end users should seek solutions that minimize downtime and risk, while providing a tangible business value proposition that will have a real economic impact on their business. In many instances, ePACs will represent a viable, easily cost-justifiable modernization solution.

ARC recommends process end users follow a stepwise approach that allows them to evolve the components of their legacy systems that have the greatest impact on their processing operations, while preserving the components that have not yet outlived their useful life. Process end users require an approach that leverages automated tools and a range of services targeted at reducing or even eliminating the downtime required to complete a migration project. When modernizing from PAC to ePAC, end users should consider the benefits of selecting an ePAC that embeds all legacy technology in its microprocessor to help ensure compliance with older ranges.

Schneider Electric's New Modicon M580 ePAC

To address the latest automation trends and market drivers for global process end users, Schneider Electric has introduced a new programmable automation controller platform with a built-in Ethernet backbone. Called the Modicon M580 ePAC, (Ethernet PAC), this new concept is designed to fill the void between a universal Ethernet backbone, a DCS, and a PAC.

With the ePAC concept, all communications – including the controller's backplane bus – are managed on an open Ethernet backbone, from the control network (SCADA, DCS, etc.) down to the field network via remote or distributed I/O. This backbone also supports a dual I/O bus, which is critically important to support redundancy requirements for many process applications.



**Schneider Electric M580
ePAC with Built-in Ethernet
Backbone**

Ethernet processing is managed directly by the controller, which has Ethernet processing built into its core. This new concept, leveraging Ethernet as its core, creates new value and positioning for automation solutions based on greater transparency and higher speed communications, to deliver deterministic solutions over standard, proven, and open

Ethernet architectures. This enables all communication, I/O, and devices to be connected via the Ethernet.

The company designed the M580 ePAC to provide full architectural flexibility, allowing authorized users to make application, configuration, and architecture modifications without interrupting the production process. It also removes existing limitations on network transparency, relying on proven and extended Ethernet routing capabilities. This makes it easy to integrate any legacy Ethernet-enabled device or system with the M580 ePAC to provide a cohesive system. This legacy integration includes busses, such as BUSX, which supports X80 local, remote, and distributed I/O; as well as legacy I/O, such as Modicon Premium I/O.

Schneider Electric's Platforms

As a global specialist in energy management with operations in more than 100 countries, Schneider Electric offers integrated solutions designed to make energy safer, more reliable, efficient, productive, and green across

multiple market segments. Schneider Electric has significant positions in energy and infrastructure, industrial processes, building automation, and data centers/networks, as well as a broad presence in residential applications.



StruxureWare Focuses on Seven Functions

Launched in 2009, EcoStruxure is a set of inter-operability standards for integrated systems architectures within Schneider Electric. StruxureWare, the company's integrated set of applications, implements the EcoStruxure vision within packaged solutions that provide plant floor-to-enterprise connectivity based on the ISA95 model. StruxureWare focuses on seven functions: power availability, process, and security at the control level; energy management, business operation, and asset management at the operations level; and sustainable resource planning at the enterprise level. StruxureWare is packaged into segment-specific "Efficiency Suites" for buildings, data centers, industry, and smart grid. These help bridge the operations and IT gap.

The company's Industry business unit plays a significant role within Schneider Electric's energy management landscape, with over 30 percent of global revenue generated from Industry customer energy efficiency solutions. Within this industrial arena, process plants are by far the highest consumers of energy. Recognizing this, Schneider Electric introduced "PlantStruxure," the company's collaborative and integrated automation architecture for industrial and infrastructure customers.

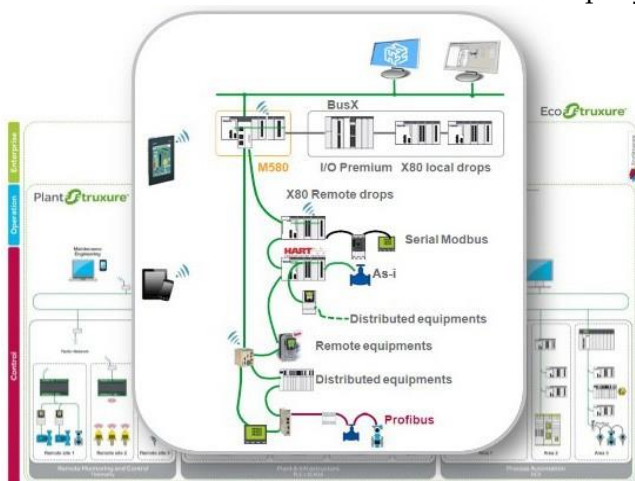

PlantStruxure Delivers Complete Solutions for Process Control and Energy Management

PlantStuxure brings together telemetry, PLC, HMI/SCADA, and DCS offerings and combines these with complete lifecycle services to help make operations more efficient. According to the company, from initial design to modernization, PlantStruxure transparently connects control, operation and enterprise levels of a process end user's business.

As it is with the new M580 ePAC, PlantStruxure is designed with Ethernet built-in as a core component to connect field, process, and plant levels to enable customers to meet their productivity, efficiency, and sustainability challenges. By enabling visibility and control of multiple processes across industrial sites in a single architecture, PlantStruxure enables energy and process data to be measured, analyzed, and used to yield a holistically optimized plant.

History of Schneider Electric's PLC/PAC Innovations

Although many suppliers can deliver portions of solutions that fulfill the automation industries requirements, only a handful of these can deliver these solutions globally and from a single source. Schneider Electric, a global, single-source supplier has been delivering solutions to the manufacturing and process industries for over 45 years. The company's milestones include its Modicon legacy, which brought the world's first PLC to market, the 084, in 1968. Modicon introduced the Modbus industrial network protocol in 1979. In 1996, Schneider Electric introduced its first PAC based on the company's Modicon family. This was a multi-disciplined platform for logic, process, and motion control with embedded web server capabilities, which was a unique innovation, and onboard data logging.



**Modicon 084,
World's First PLC**

Schneider Electric also acquired Citect in 2006, adding and integrating the portfolio of one of the world's leading providers of industrial automation software into its automation and control solutions offering. The integration also encompassed Citect's field operations (sales, professional services and training) team to further strengthen Schneider Electric's SCADA, HMI, and MES solutions, capabilities, and services. This legacy, coupled with the fact that Schneider Electric is a world leader in providing power and energy management devices and software, creates a solid foundation for creating the concept for and introducing the M580 ePAC.

M580 ePAC Value Propositions

Any solution intended for use on the plant or factory floor must offer overall system reliability, robustness, and sustainability to help ensure safe, non-stop operation. For many applications, new products must be able to

operate without problems for the next 20 years. This is often the highest priority for any processing application. Most industrial applications require zero downtime, as the financial and human consequences could be tremendous if an automation process stops for any unplanned reason.

This zero-downtime principal is integral to the design and component selection of the M580 ePAC, as it has been since the company introduced the first PLC in 1968. The company has validated the design in the harshest environments, such as hot temperatures, marine or corrosive environments, vibrations, etc., and all electronic components are also checked and validated prior to assembly. Many auto-checks are performed transparently to ensure no memory corruption, which can correct itself when one bit flip has been detected. As soon as the system detects a divergence, it automatically goes into a safety stop mode, recording all last internal events within the system; such as last instructions processed by microprocessor, memory state, and task scheduling; and activating all outputs in fallback mode.

Failure Prediction

To catch an issue before it becomes a problem, diagnostics must be available to perform predictive maintenance on the complete system. This approach helps avoid unscheduled downtime and manage device replacement before it can fail and impact production. With the M580 ePAC system, a high level of internal diagnostics is available on both local and remote configurations, enabling the system to anticipate failures and users to take corrective actions. Diagnostics can be monitored through a “diagnostic buffer” feature, available locally on Schneider Electric HMIs or SCADA systems, or remotely on web pages through smartphones or tablets.

Modicon PAC Family



Modicon PAC Family Designed to Help Ensure Long-term Investment Protection

Investment Protection

Managers in process plants are always anxious to select solutions that are likely to have a long service life to help protect their technology investment. While system reliability is important, it’s also important to consider the technology choices integrated into automation solutions. With today’s rapid advancements in technology, it can be very challenging to select

technology today that will still be available and recognized in 20 years. That is why Schneider Electric chose architecture based on standard Ethernet as the best guarantee for long term sustainability, leveraging open and proven technologies with strong market acceptance.

Schneider Electric has kept in mind the need for a long service life when designing and selecting the components for the new for the M580 ePAC, as well as with PlantStruxure's hardware, firmware, and software. These leverage SPEAr microprocessor technology through a long-term partnership with ST Microelectronics for core processors.

Benefits for Schneider Electric customers to upgrade their systems to M580 ePAC

- Reduced cost to upgrade
- Minimized schematic drawing changes
- Reduced program re-engineering
- Reduced training on new technology
- Existing networks and wiring can be left intact
- Reduced changes to I/O, leveraging X80
- Minimized downtime
- Reduced risks
- No need to "rip and replace"
- Extended lifecycle of existing spare parts
- Natively integrate I/O of TSX Premium range in M580 ePAC configuration

Investment protection also relates to the ability to retain existing automation components when expanding an existing platform or -modernizing to a new platform. With the new M580 ePAC, Schneider Electric customers can continue to use their existing X80 local, remote, and distributed I/O from the Modicon M340. This can create savings in a number of different areas, including acquisition, engineering, installation, cabling, maintenance, and training. This ap-

proach can also minimize costly downtime by eliminating the need to "rip and replace" the I/O already installed in the plant.

Installed Base Upgrade

Technology upgrade is a key issue across the process industries. Companies and automation suppliers are being asked to provide smooth upgrade paths from legacy systems to their latest systems.

The M580 ePAC was designed to leverage a user's existing assets and installed base by leveraging existing X80 I/O to reduce training and spare parts requirements and allowing easier substitution between ranges.

In addition to appropriate technology solutions (such as the M580 ePAC and PlantStruxure), Schneider Electric has a dedicated "Installed Base Program" that focuses on the needs of the company's existing users, including technology upgrades. This program involves working closely with customers to simplify their operations and minimize the time, cost, and effort

required to convert their various existing applications to integrated Schneider Electric solutions.

Energy Efficiency and Operational Intelligence

Schneider Electric's PlantStruxure with Ethernet backbone, StruxureWare software, and new M580 ePAC all work together to enhance plant operational efficiency, while enabling a standard "energy-aware" architecture. Users can manage process, instrumentation, and power data in real time to improve production control while optimizing energy consumption. Operational intelligence and analytics are other key performance-enhancing capabilities.

The company's Collaborative Automation Partner Program (CAPP) also enables users to take advantage of third-party solutions that work seamlessly with the system to provide incremental functionality. This is another benefit of the M580 ePAC being designed with an open Ethernet backbone, which enables and optimizes connectivity and communications with these third party solutions.

M580 ePAC Competitive Differentiators

Building on its heritage and existing technology base, Schneider Electric designed the M580 ePAC using the latest, most powerful state-of-the-art microprocessor technology.

Architecture



**M580 ePAC's ARM
Microprocessor**

The M580 ePAC is based on chips that leverage ARM (Advanced RISC Machine) architecture, a family of 32-bit chip sets. ARM does not manufacture its own electronic chips, but licenses its designs to other semiconductor manufacturers. Thousands of technology suppliers use ARM technologies, which provide benefits such as reduced costs, power requirements, and heat generation compared to other more complex chip designs. These ARM designs are commonly found in smartphones; flat-panel digital televisions; and mobile, laptop, tablet and notepad computers. The ARM processor is built on a reduced number of transistors, making this platform very efficient in term of MIPS per watt. The reduced complexity and simpler designs allow companies to build low-energy systems on a

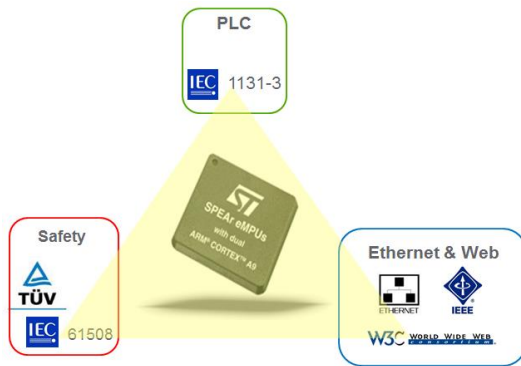

M580 ePAC's ARM Microprocessor Has IEC, TÜV, and W3C Certifications

chip for an embedded system incorporating memory and interfaces. Alternatively, the use of simpler designs allow for more efficient multi-core CPUs and higher core counts at a lower cost, enabling higher levels of processing power and improved energy efficiency. These characteristics provide strong business values to the user. Maximizing a powerful platform that consumes less energy is a primary benefit. Also, the durability of the ARM processor, combined with Schneider Electric's strong partnership with ST Microelectronics, ensures long-term product reliability and support.

The ARM microprocessor used in the M580 ePAC is a SPEAr dual-core, multi-function CPU, built by ST Microelectronics through a partnership with Schneider Electric. Schneider Electric entered into a long-term agreement with the chip supplier to help ensure the availability of the M580 ePAC's ARM microprocessor for 20 years. This will provide a high level of assurance to Schneider Electric's new and legacy customers that they can rely on the M580 ePAC and its ARM microprocessor technology for continuous support during the full lifecycle of their applications.

This SPEAr dual-core, multi-function CPU processor runs at 600 MHz and leverages the latest error correction code (ECC) technology and error correction designs for data communications and storage. It also meets the requirements of high-speed, wide-bandwidth, and fault-tolerant systems. This microprocessor enables high-speed communication on its backplane thanks to embedded Ethernet and conformance to the W3C-certified IEEE 1588 time stamp protocol. It also has native, built-in TÜV-certified safety features and adheres to the IEC 61508 functional safety standard for electrical/electronic/programmable electronic safety-related systems up to SIL 3 safety integrity levels. Safety is integrated into the M580 ePAC design, a characteristic that provides a strong business value to the user by making safety an integral part of their process.

Using ARM technologies enables the company to leverage some of the best microprocessor designs, while using a standard platform that is available from the largest chip makers. This provides a high level of assurance that Schneider Electric will be able to support the platform for its customers for the requested 20 years. Using ARM as a standard microprocessor platform enables the company to port, reuse, and improve its key software

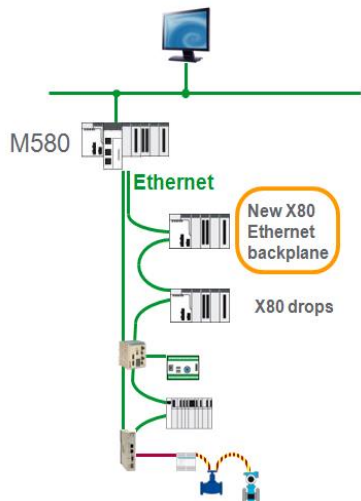

Ethernet Backplane Provides Connectivity and System Flexibility, so Adding or Modifying Drops Can Be Done On The Fly

technologies with a low impact on the M580 ePAC's architecture. Finally, the return of experience (REX) on this technology is large. The ARMs installed in Schneider Electric's M340 PAC are running in nearly 200,000 applications globally, including on both military ships and in nuclear plants.

Flexibility

The M580 ePAC includes typical PAC capabilities, such as five programming languages certified for IEC 61131-3 compliance; a complete range of I/O modules; four levels of CPUs to deliver a scalable solution; communication or expert modules with features for applications, such as RTUs, communications, PID, etc.; as well as the sufficient processing power to manage complex targeted processes.

Beyond these, however, in addition to its open Ethernet backbone, the M580 ePAC offers a number of key additional capabilities. These include the ability to change configurations on the fly, offering users the flexibility to make needed changes without having to stop the process. This includes adding X80 I/O drops and devices directly on the Ethernet network. Users can change the initial architecture, add a new drop in the configuration, or add a new module in an existing drop. Digital and analog I/O modules can be added or deleted within a drop, channel configuration parameters modified, hot-swapped modules automatically reconfigured, and applications modified online while the process is running.

Remote, distributed, and standard equipment can be mixed on the same Ethernet field network with complete software integration. Thanks to embedded CPU switches and drops (including fiber optics), loops can be daisy chained with no external switches. Fieldbus and expert functions are also available via remote drops for Modbus, actuator sensor interface (AS-i), HART modules, etc.

The ePAC flexibility opens up wide architectural possibilities. Embedded smart solutions overcome most traditional system constraints. For example, embedded fiber optic converters enable increased distances of up to 15 km between remote drops. In addition, Wi-Fi connections, via a dedicated module that can be added to the M580 ePAC, provide efficient and secure access points. Service ports embedded in all Ethernet modules provide ex-

tra connections without incremental costs. The architecture integrates embedded Ethernet switches and a variety of embedded field buses interfaces, such as Modbus serial, AS-i, RTU, and Profibus.

Cybersecurity

To address today's critical cybersecurity issues, security is built into each M580 ePAC to provide an open, yet fully secured system. Advanced cybersecurity features help ensure the systems are protected from cyber-attacks.

To address today's critical cybersecurity issues, security is built into each M580 ePAC to provide an open, yet fully secured system. Advanced cybersecurity features help ensure the systems are protected from cyber-attacks. Each M580 ePAC can be secured using encrypted logins and passwords for every application. Unnecessary services can be disabled and checks can be performed to verify the integrity of the controller's programming tool and firmware as well as the nominal behavior of the system itself.

Transparency

Data transparency is another challenging issue for end users in process plants, who require a "single version of the truth," to help ensure that they make the right decisions. The M580 ePAC Ethernet backbone design can be configured to enable information to flow directly without any application between the controller and field devices; HMI/SCADA systems; engineering workstations; asset management systems; and other intelligent

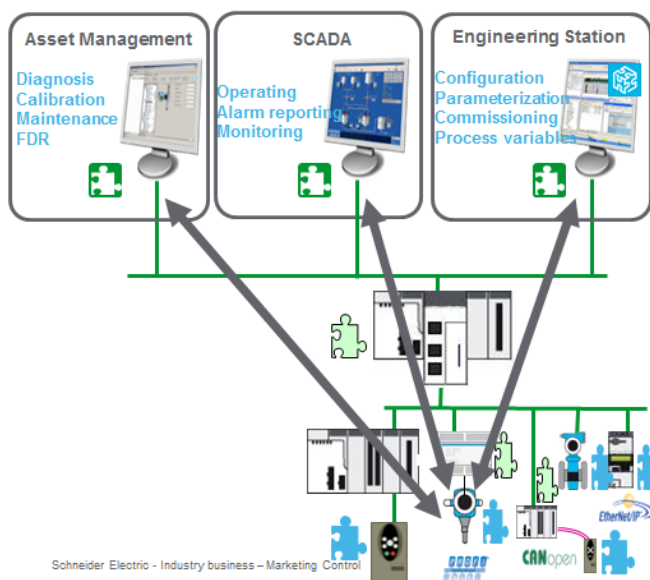

Data Transparency Enables a "Single Version of the Truth"

devices, such as drives. Authorized users can configure and tune parameters for all connected devices from everywhere on the system network. The Ethernet backbone manages the communication and routing capabilities to help maximize performance. All M580 ePAC diagnostic information can be accessed from a programming tool, HMI/SCADA system, or from a PC, tablet, or smartphone web browser.

The system provides native support for both EtherNet/IP and Modbus TCP. Since all its Ethernet modules and CPUs contain double profiles (a key differentiator for the M580), users can take

advantage of off-the-shelf connectivity to what is, collectively, the largest global installed base of Ethernet devices.

This native transparency extends to any third-party device connected to the network. FDT Device Type Managers (DTMs), for example, standardize the communication and configuration interface between field devices and the host systems. The DTMs provide a unified structure for accessing device parameters, configuring and operating the devices, and diagnosing problems from the system using FDT frame applications developed by the device manufacturers themselves.

M580 ePAC Target Applications

Schneider Electric is targeting the M580 ePAC towards process end users, particularly end users who are currently using larger PLC- or PAC-based

Schneider Electric is targeting the M580 ePAC towards process end users, particularly end users who are currently using larger PLC- or PAC-based systems in energy-intensive industries, such as water & wastewater, food & beverage, upstream and midstream oil & gas, and metals & mining where the company's StruxureWare integrated energy management solutions can play a key role in reducing energy costs and energy-related emissions.

systems in energy-intensive industries, such as water & wastewater, food & beverage, upstream and midstream oil & gas, and metals & mining where the company's StruxureWare integrated energy management solutions can play a key role in reducing energy costs and energy-related emissions. Schneider Electric believes that users in these and other process industries – including hydropower -- are in the best

position to take advantage of the platform's key value propositions, unique characteristics, competitive differentiators, and multi-disciplined functionality to help lower total cost of ownership.

When it comes to market growth, the oil & gas, mining & metals, and water & wastewater industries are projected to be some of the fastest growing users of PACs over the next five years. In oil & gas, these segments include upstream and midstream pipeline processing. The growth drivers for those industries are primarily the accelerating global product demand and increasing need for capital spending towards energy and infrastructure. Drivers for this switching rate growth are the extensive use of PLCs in those industries, the natural evolution to the multi-discipline functionality, and cannibalization of higher priced system products.

Water & Wastewater

The unique capabilities and characteristics of the M580 ePAC make it well-suited for a number of water & wastewater industry applications, including

The unique capabilities and characteristics of the M580 ePAC make it well-suited for a number of water & wastewater industry applications, including both water and wastewater treatment plants, remote pump stations, and pipeline network management.

both water and wastewater treatment plants, remote pump stations, and pipeline network management. Schneider Electric Altivar Process drives have been fully integrated into the M580 architecture so that they can be included directly in RIO ring and leverage many services, such as automatic reconfiguration when replacing devices. Also, RTU modules managed in a M580 local rack interoperate with third-

party SCADA packages and Accutech wireless devices. Finally, third-party HART modules are plugged into the M580 platform to interface with field instruments for control purposes and on-line diagnostics.

Food & Beverage

Schneider Electric believes that the M580 ePAC is ideally suited for a number of challenging food & beverage industry-specific applications, including both confectionary and liquid product plants. For example, weighing modules can be integrated using M580 local and remote drops, with ATEX certification provided for most X80 modules as well as for M580 CPUs. The company has also developed AS-i connectivity from remote locations (RIO drops) specifically for the food & beverage industry.

Mining & Metals

In mining & metals, target segments for the M580 ePAC include cement and material handling, applications in which the environmental conditions will chew up all but the most rugged hardware. Here, Schneider Electric offers a complete range of hardened, conformal-coated and extended temperatures for X80 I/O and expert modules, as well as M580 CPUs designed for harsh applications. Also, for applications that require PROFIBUS interoperability, the company offers a new PROFIBUS remote master module for the M580 ePAC.

Hydropower

For the hydropower segment, the M580 ePAC is well-suited for medium-sized plants. Here, Schneider Electric's ERT modules used with the M580

ePAC can provide cybersecurity-certified time stamping precision of 1ms at the source.

Energy Efficiency

Regardless of industry or application, Schneider Electric can provide active energy management products and solutions to enable process end users to

The company's energy management solutions include procedures for auditing and measuring the process application to establish a baseline and identify areas for improvement around energy consumption.

realize and sustain energy savings. The company's energy management solutions include procedures for auditing and measuring the process application to establish a baseline and identify areas for improvement around energy consumption. Company experts can then install the devices needed to record and measure energy usage. Processes can then be optimized using

automation devices such as AC drives and controllers and continuously monitored using software tools to sustain the improvements.

Power and control have traditionally been separate worlds. Today, however, the user can only optimize their efficiency and reduce operating costs by implementing strategies that combine both. The M580 ePAC, combined with PlantStruxure, is designed to combine process and energy disciplines into one system, providing users across all industries with a single, highly effective solution for process and energy control and management.

Summary and Conclusions

Today's industrial process plants struggle to improve flexibility, process control, productivity, and regulatory compliance; while reducing energy and raw material consumption. This has increased the requirements for both automation and energy management. At the same time, technology advancements have made controllers both more powerful and communicative.

Increasing processing power and networking technologies, along with a lower cost base, enable today's PACs to address many applications that would have been impossible in the past. This includes the use of multi-core microprocessors with certified safety functionalities, the integration of Ethernet to the backplane so the network becomes the controller within a

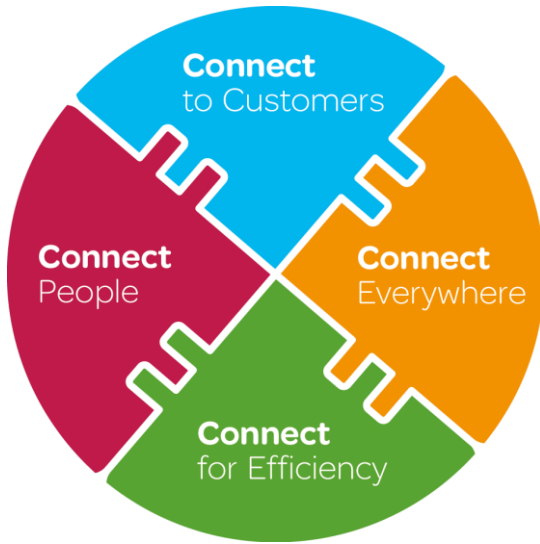

Schneider Electric's Connect Program

distributed intelligence configuration, breaking down barriers to real-time data access to eliminate any time latency and inconsistency, and sharing data at all levels of an organization. At the same time, adding new systems to processing requires sound migration strategies and flexibility, leveraging existing remote and distributed I/O as well as legacy installed bases whenever possible, and being able to make changes “on the fly,” without always having to shut down the process.

Schneider Electric's new M580 ePAC, with Ethernet built-in as part of its core, addresses all of the above market requirements. By embedding standard, unmodified Ethernet directly into the controller, the

M580 enables more transparency, flexibility and openness; managing data in a fully deterministic and synchronized fashion. Schneider Electric has developed an open and collaborative framework, PlantStruxure, for process automation and energy management linked to the enterprise. In addition to providing significant customer value, PlantStruxure and the new M580 ePAC go a long way to helping the company meet the strategic objectives of its multi-year “Connect” initiative to create a unified customer experience that bridges the many strategic acquisitions the company has made in recent years.

The company's background in industrial automation and energy management has helped bridge a functionality gap across the enterprise. PlantStruxure, along with the M580 ePAC, creates a common environment in which these applications can coexist and share information. This environment embraces standard technologies, work processes, and best practices; ensuring a wide range of choices for the process end user.

ARC believes that the concept of an Ethernet-based PAC will be well received in the marketplace and while, to the best of ARC's knowledge, Schneider Electric is first to market with this type of product, we believe that many other leading suppliers in the automation industry may soon follow suit with their own “ePACS.”

Analyst: Craig Resnick

Editor: Paul Miller

Acronym Reference: For a complete list of industry acronyms, please refer to www.arcweb.com/research/pages/industry-terms-and-abbreviations.aspx

| | |
|---|---|
| ARM Advanced RISC Machine | ISA Intl. Society of Automation |
| AS-i Actuator Sensor Interface | IP Industrial Protocol |
| ATEX Atmospheres Explosives | IT Information Technologies |
| BYOD Bring your own device | MHz Megahertz |
| CAPP Collaborative Automation Partners Program | ODVA Open Device Vendors Association |
| CAPEX Capital Expenditures | MES Manufacturing Execution System |
| CPU Central Processing Unit | MIPS Million Instructions per Second |
| DCS Distributed Control System | PAC Prog. Automation Controller |
| DDT Derived Data Types | PID Proportional Integral Derivative |
| DTM Device Type Manager | PLC Programmable Logic Controller |
| ECC Error Correction Code | REX Return on Experience |
| EAM Enterprise Asset Management | RTU Remote Terminal Unit |
| ERP Enterprise Resource Planning | SCADA Supervisory Control and Data Acquisition |
| FDT Field Device Tool | SCM Supply Chain Management |
| HMI Human Machine Interface | SIL Safety Integrity Level |
| I/O Inputs/Outputs | TÜV Technical Inspection Association |
| IEC Intl. Electrotechnical Commission | W3C World Wide Web Consortium |

Founded in 1986, ARC Advisory Group is the leading research and advisory firm for industry. Our coverage of technology from business systems to product and asset lifecycle management, supply chain management, operations management, and automation systems makes us the go-to firm for business and IT executives around the world. For the complex business issues facing organizations today, our analysts have the industry knowledge and first-hand experience to help our clients find the best answers.

All information in this report is proprietary to and copyrighted by ARC. No part of it may be reproduced without prior permission from ARC. This research has been sponsored in part by Schneider Electric. However, the opinions expressed by ARC in this paper are based on ARC's independent analysis.

You can take advantage of ARC's extensive ongoing research plus experience of our staff members through our Advisory Services. ARC's Advisory Services are specifically designed for executives responsible for developing strategies and directions for their organizations. For membership information, please call, fax, or write to:

ARC Advisory Group, Three Allied Drive, Dedham, MA 02026 USA
Tel: 781-471-1000, Fax: 781-471-1100
Visit our web pages at www.arcweb.com



3 ALLIED DRIVE DEDHAM, MA 02026 USA 781-471-1000

USA | GERMANY | JAPAN | KOREA | CHINA | INDIA | BRAZIL | ARGENTINA